



# LIGHTING ATLAS VOLUME 1

UNITED ARAB EMIRATES  
FRANCE  
TURKEY  
UNITED STATES OF AMERICA  
ITALY  
AUSTRIA  
SPAIN  
IRAN  
KUWAIT  
UNITED KINGDOM  
SWEDEN



LIGHTING ATLAS  
VOLUME 1



CASTALDI LIGHTING S.P.A.

Via Benvenuto Cellini, 8  
21012 Cassano Magnago (Varese) Italy  
info@castaldilighting.it  
Tel: +39.0331.706.91

[www.castaldilighting.it](http://www.castaldilighting.it)

---

## COMPANY PROFILE

---

Castaldi Lighting was founded in 2011 from the merger between “Ing. Castaldi Illuminazione” and “Norlight”, two well-established companies in the lighting industry. These Companies had successfully acquired a prominent position respectively in the Outdoor and Indoor segments, with a particular focus on Office Buildings, Retailing, Public areas etc. and on Specialties applications (e.g. Pharma industry, Hospital, etc.).

Castaldi and Norlight products are the result of the continuous commitment towards Research & Development, Lighting Design, Quality Assurance and Control over production processes to accomplish also the most challenging requirements of “Custom made” productions.

The Company’s production is made in Italy, in its facilities located north of Milano. Thanks to its fully integrated production system and the in-house, product control and testing laboratories, Castaldi Lighting achieves the highest quality and performance standards. Castaldi Lighting operates all over the world: exports 70% of its production with a significant presence in the USA, France, Scandinavia and the Middle East. In addition, the Company has always been very successful in “Custom made products” thanks its remarkable competence in developing high performing solutions for different requirements.

Castaldi Lighting cooperates with all the major international Architecture and Design firms and then its products are installed throughout the world in premier locations: in Abu Dhabi at the Ferrari World Park, in the Sky Tower Shams and at the Cleveland Clinics, at Westminster University in London, in Zaha Hadid’s City Life residences in Milan, at the Italian Space Agency in Rome, at the Atelier Renault Champs-Élysées in Paris and in many other contemporary architectural sites.

---

## CONTENTS

---

- |    |  |     |  |
|----|--|-----|--|
| 6  | <b>LIGHTING ATLAS</b><br>World Map                   | 88  | <b>IMAM REZA SHRINE</b><br>MASHHAD                                       |
| 8  | <b>ABU DHABI INTERNATIONAL AIRPORT</b><br>ABU DHABI  | 92  | <b>PLATEAU SPORTIF AVANNE-AVENEY</b><br>BESANÇON                         |
| 14 | <b>DOCKS DE MARSEILLE</b><br>MARSEILLE               | 97  | INTERLUDE<br>Photo by Tom Vack   |
| 24 | <b>ANKARA GATES</b><br>ANKARA                        | 110 | <b>NEIGHBORHOOD PARK</b><br>SAN DONÀ DI PIAVE                            |
| 28 | <b>INGERSOLL RAND HEADQUARTERS</b><br>DAVIDSON       | 114 | <b>IULM</b><br>MILANO  |
| 33 | NOTES FROM PRODUCTION<br>Photo by Adriano Brusaferrì | 120 | <b>SAFAT HOME</b><br>KUWAIT CITY   |
| 50 | <b>CLEVELAND CLINICS</b><br>ABU DHABI                | 124 | <b>CITY LIFE</b><br>MILANO   |
| 56 | <b>ASI AGENZIA SPAZIALE ITALIANA</b><br>ROMA         | 130 | <b>BENNET VAPRIO D'ADDA (MI)</b><br>VAPRIO D'ADDA                        |
| 66 | <b>STIFT MELK</b><br>MELK                            | 136 | <b>UNIVERSITY OF WESTMINSTER</b><br>LONDON                               |
| 72 | <b>PALAVELA</b><br>TORINO                            | 140 | <b>LITOGRAFISKT MUSEUM GRUDES ATELJE &amp; STENTRYCKERI</b><br>STOCKHOLM |
| 76 | <b>IM CLINIC</b><br>BARCELONA                        | 146 | <b>ULRIKSDALS</b><br>SOLNA   |
| 84 | <b>SKY TOWER SHAMS</b><br>ABU DHABI                  | 150 | <b>BIBLIOTECA CIVICA ROSIGNANO MARITTIMO (LI)</b><br>ROSIGNANO MARITTIMO |
|    |  | 156 | CREDITS  |





N 24° 28' 35" | E 54° 22' 12"

①

Abu Dhabi

## ABU DHABI INTERNATIONAL AIRPORT

Project by  
Kohn Pedersen Fox Associates

DOMINATING A KEY POSITION IN THE GLOBAL RACE FOR FAST-EXPANDING LUXURY AIR TRAVEL AND TRANSFER POINTS, THE NEW MIDFIELD TERMINAL COMPLEX WILL PROCESS OVER 50 MILLION TRAVELLERS EACH YEAR TO MEET THE NEEDS OF THE RAPIDLY EXPANDING MIDDLE EAST CAPITAL.

### INSTALLED LAMPS

#### L4 - REGLETTE



#### COVE LIGHTING FIXTURE

Housing consisting of powder-coated extruded aluminium profile. Available on different lengths to compose every kind of geometry.

#### S7/S8

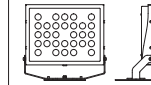

#### SPOTLIGHT - surface mounted adjustable and lockable projector.

Housing consisting of powder-coated stainless steel body, as the bracket. S7 and S8 have both an elliptical beam.

#### B1 - POLO INOX



#### 316L STAINLESS STEEL BOLLARD

Vehicle restraint designed to be placed on concrete floor. PC diffuser made to resist at high ambient temperature.

#### L5-L5b - REGLETTE



#### SURFACE MOUNTED

Housing consisting of powder-coated extruded aluminium profile. L5 available 1 or 2x50W. Tiltable reflectors to adjust the direction of the beam.

#### L7 - NHB7

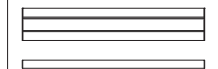

#### CEILING/WALL RECESSED

Continuous wall and glass screen mounted linear luminaire. Asymmetrical beam. Anti glare screen reduce the visibility of the led source to have a comfortable light.

#### ADDITIONAL CUSTOM MADE PRODUCTS ACCORDING TO DESIGNER'S AND ARCHITECT'S PROJECT









N 43° 17' 49" | E 05° 22' 51"



2

Marseille

## DOCKS DE MARSEILLE

Project by  
5+1 AA Alfonso Femia Gianluca Peluffo

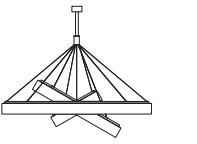
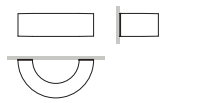
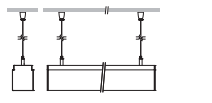
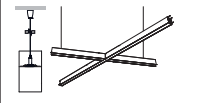
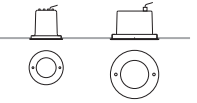
LES DOCKS ARE HISTORICALLY LOCATED ON THE AXIS BETWEEN THE SEA AND THE CITY; THIS STRONG AND DISTINCT CUT OF THE TERRITORY LETS THE ARCHITECTS ALFONSO FEMIA AND GIANLUCA PELUFFO TRANSFORM THIS BUILDING INTO A PLACE OF DIALOG. THEIR CONCEPT IS DESIGNED FOR THE INTEGRATION OF THE TWO CITY SOULS: THE URBAN ONE AND THE MARITIME ONE.

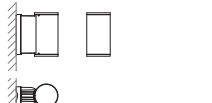
INSTALLED LAMPS			
<p><b>BUBBLE TOURBILLON</b></p>  <p>SUSPENSION CONFIGURATION CUSTOMIZABLE - LED UP TO 1055W</p> <p>Smooth opal polycarbonate diffuser, injection moulded, shock-resistant, anti-ageing.</p>	<p><b>HALF 500 / 800</b></p>  <p>WALL MOUNTED/CEILING</p> <p>Uniform light throughout its entire volume - LED 20W / 40W Extruded calendered aluminum body, powder-coated.</p>	<p><b>SLEVO SUSPENSION</b></p>  <p>HIGH EFFICIENCY LED UP 73W</p> <p>Visual comfort with reductions in luminance levels in upper emission corners.</p>	<p><b>SLEVO SNAKE</b></p>  <p>Custom made version. Designed by Arch. Alfonso Femia</p>
<p><b>D42_TELLUX T2 / T3</b></p> 	<p><b>CEILING RECESSED IP66 - LED UP 37W</b></p> <p>Tempered safety glass, mechanical and thermal shock resistant.</p>	<p><b>D64 ICE</b></p> 	<p><b>GROUND RECESSED IP67 - LED UP TO 18W</b></p> <p>Tempered safety glass - 10 mm thickness, mechanical and thermal shock resistant.</p>
<p><b>D55_FLEX TO</b></p> 	<p><b>SPOT LIGHTS IP65 - LED 6.5W</b></p> <p>Rotation on 2 axes 360ff-130ff.</p>	<p><b>D20_DUETTO T3</b></p> 	<p><b>WALL MOUNTED IP66 - LED UP TO 45W</b></p> <p>Safety tempered glass diffusers. Extra-pure aluminium reflector.</p>

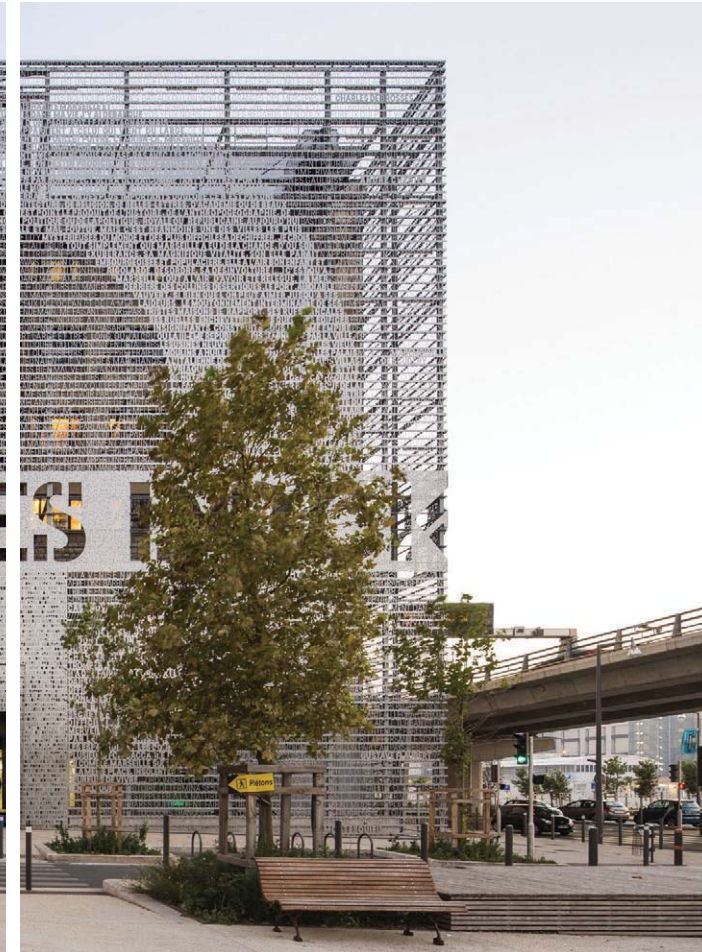





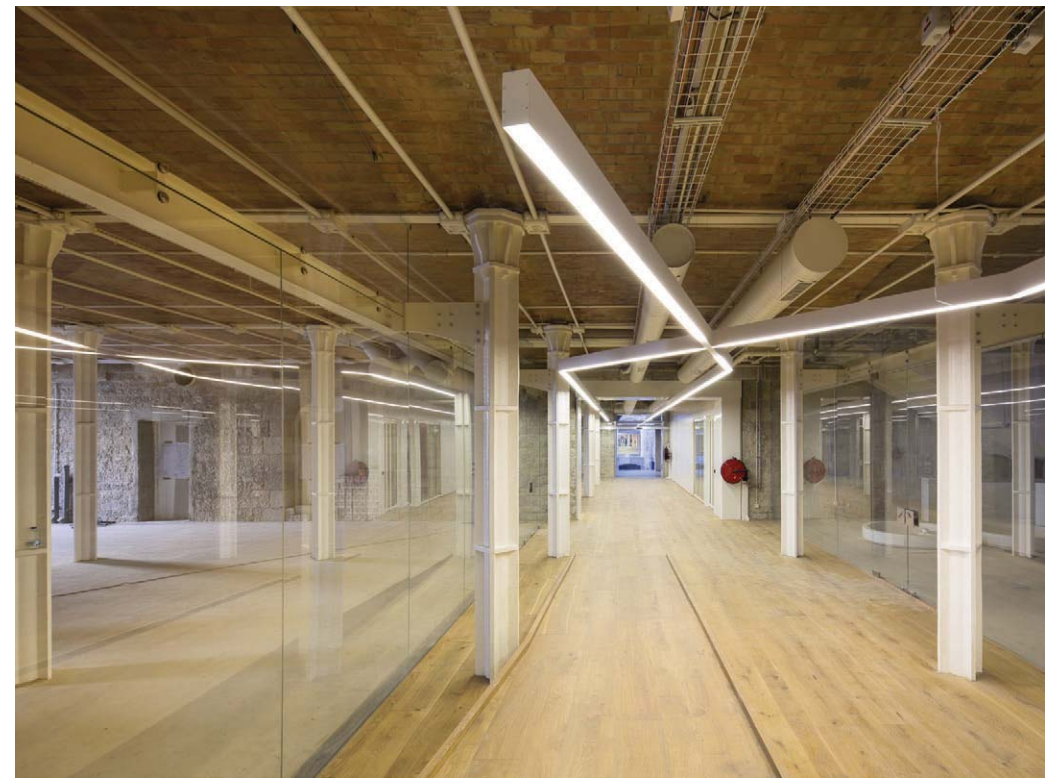
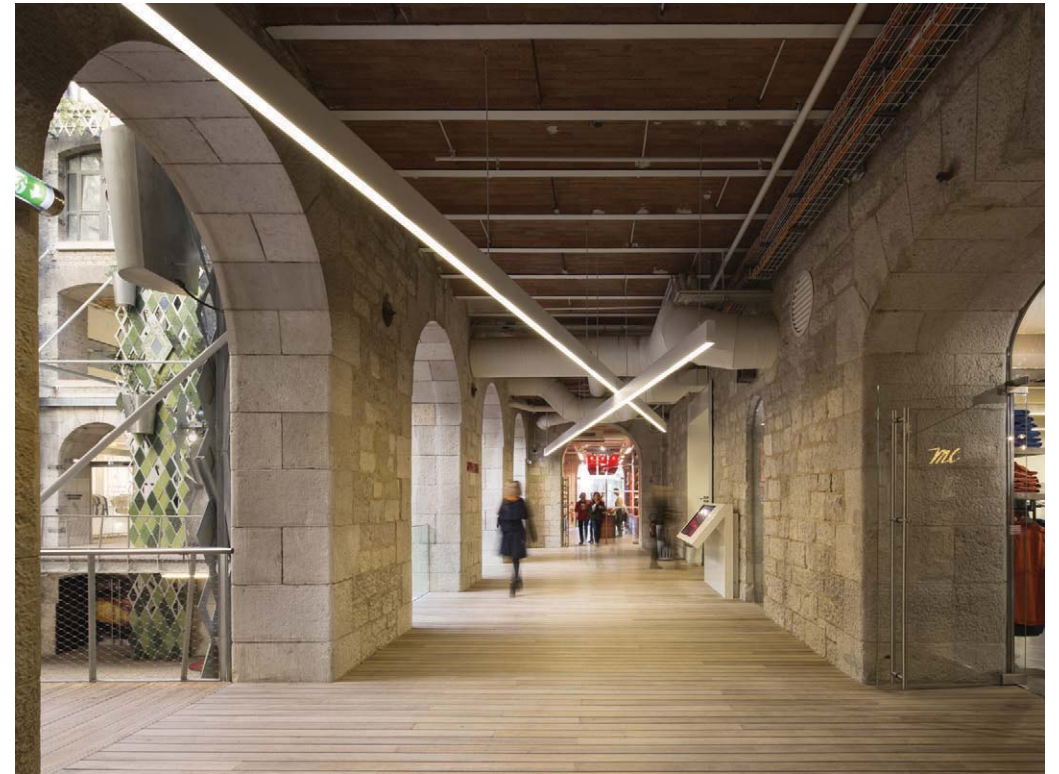



N 39° 55' 11" | E 32° 51' 15"

3

Ankara

## ANKARA GATES

Project by  
Citylight Professional Lighting Systems

ANKARA WAS ATATÜRK'S HEADQUARTERS FROM 1920 AND IS THE CAPITAL OF THE REPUBLIC OF TURKEY SINCE ITS FOUNDING IN 1923, REPLACING ISTANBUL AFTER THE FALL OF THE OTTOMAN EMPIRE. LOCATED IN CENTRAL ANATOLIA, ANKARA HAS 5 MAIN STREETS THAT CONNECT IT THE MAJOR CITIES OF THE REGION: ISTANBUL, SAMSUN, ESKISEHIR, ESENBOGA AND KONIA. ALL THE PEOPLE ENTERING IN THE CITY PASS THROUGH A GATE THAT CELEBRATES THE GREATNESS OF THE CAPITAL CITY.

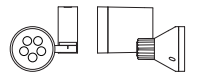
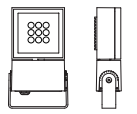
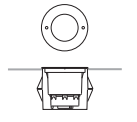
INSTALLED LAMPS	
<p>D55_FLEX T1</p> 	<p>SPOT LIGHTS IP65 - LED 13.5W</p> <p>Rotation on 2 axes 360°-130°</p>
<p>D57_FLAT P2</p> 	<p>SPOT LIGHTS IP65 - LED UP TO 52W</p> <p>Versatile and dynamic lighting system with 6 different beams</p>
<p>D44_TELLUX T3</p> 	<p>GROUND RECESSED IP67 - LED UP TO 37W</p> <p>Tempered safety glass - 12mm thickness, mechanical and thermal shock resistant.</p>

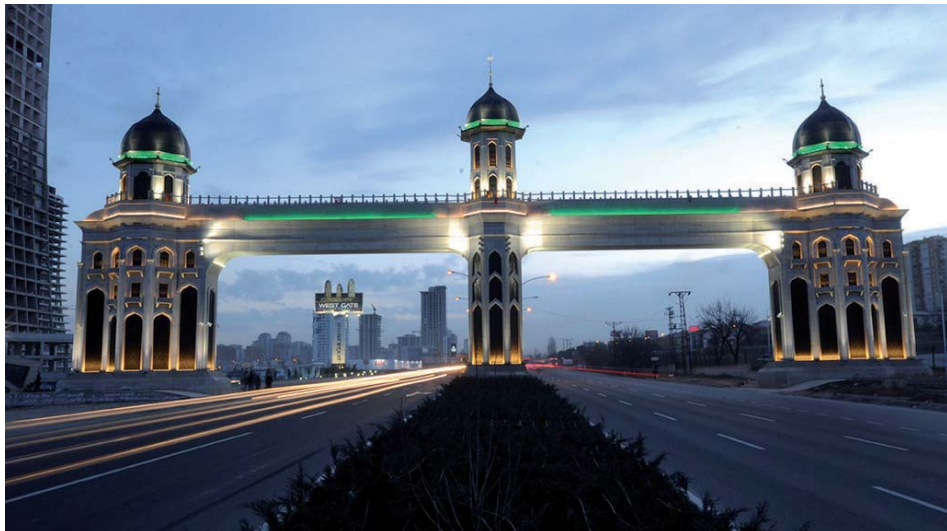



N 35° 29' 28" | W 80° 49' 58"

4

Davidson

## INGERSOLL RAND HEADQUARTERS

Project by  
Studio Fusion

THE GOAL OF THIS PROJECT WAS TO HAVE A MORE SUSTAINABLE DESIGN, WHICH WAS ACCOMPLISHED BY MULTIPLE SOLUTIONS; SUCH AS LED LIGHTS AND AUTOMATIC LIGHTING, ENERGY EFFICIENT APPLIANCES, GREEN CLEANING PRODUCTS, AND RECYCLED DEBRIS FROM THE DEMOLITION.

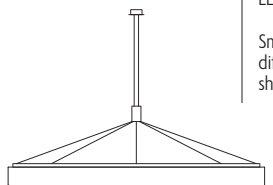
INSTALLED LAMPS	
BUBBLE 3000	SUSPENSION DIAMETER 3000mm LED 600W
	Smooth opal polycarbonate diffuser, injection moulded, shock-resistant, anti-ageing.





NOTES FROM PRODUCTION

---

photo by Adriano Brusafferri









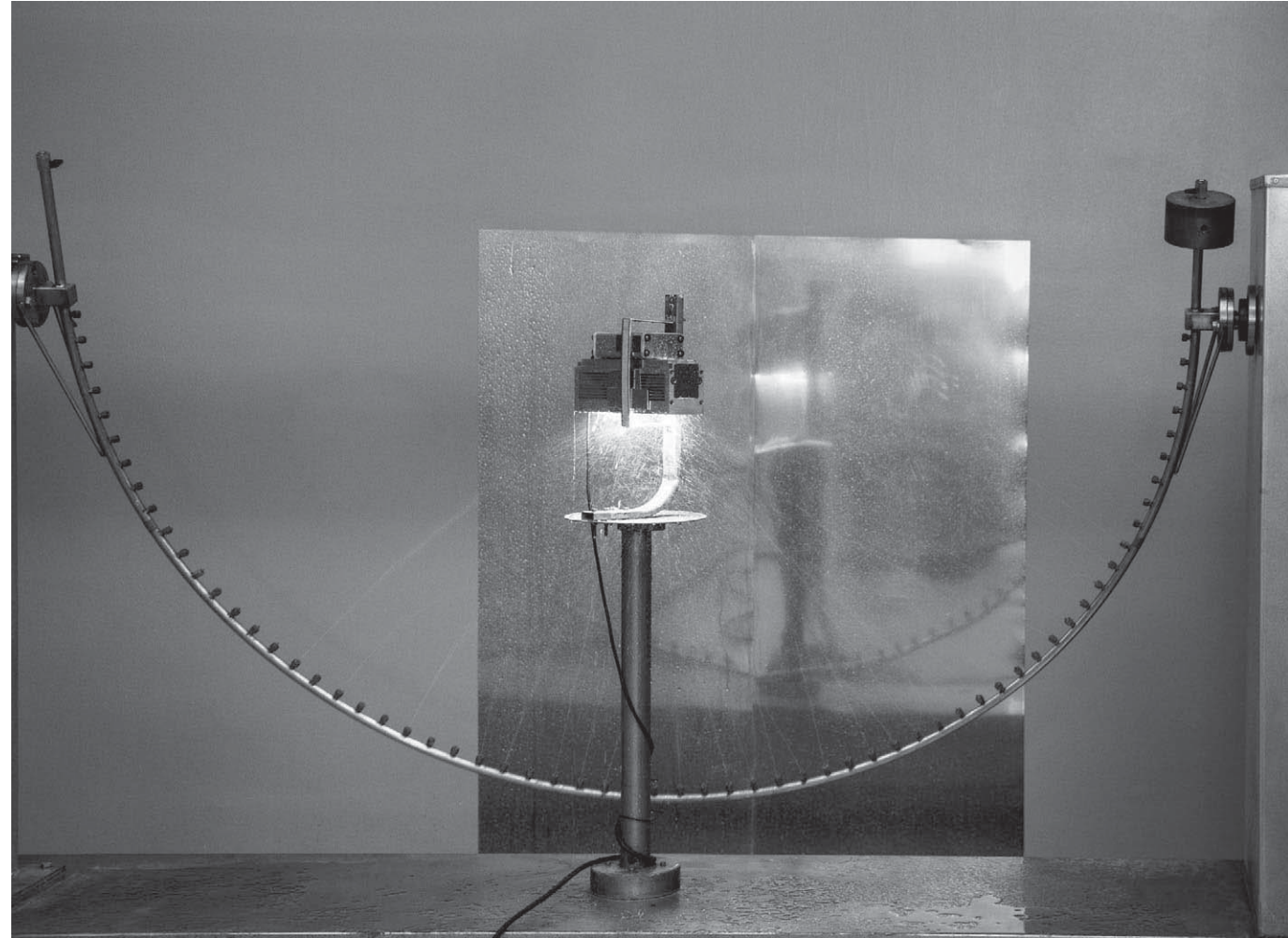
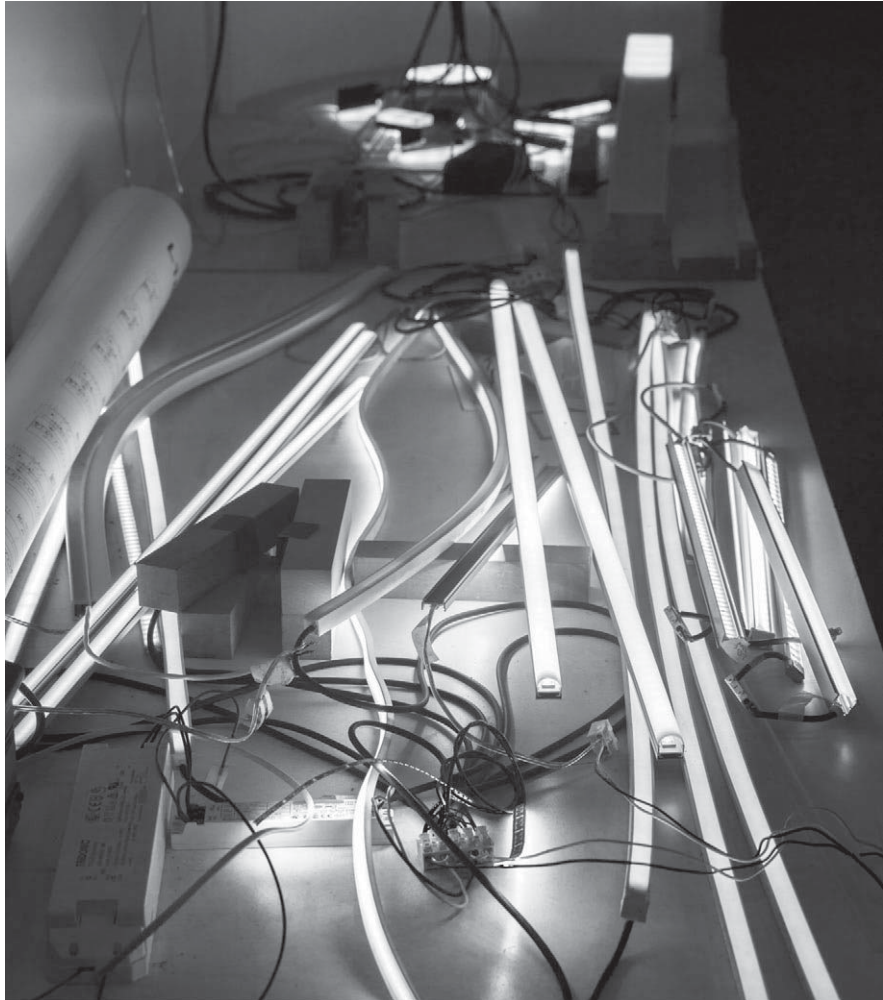

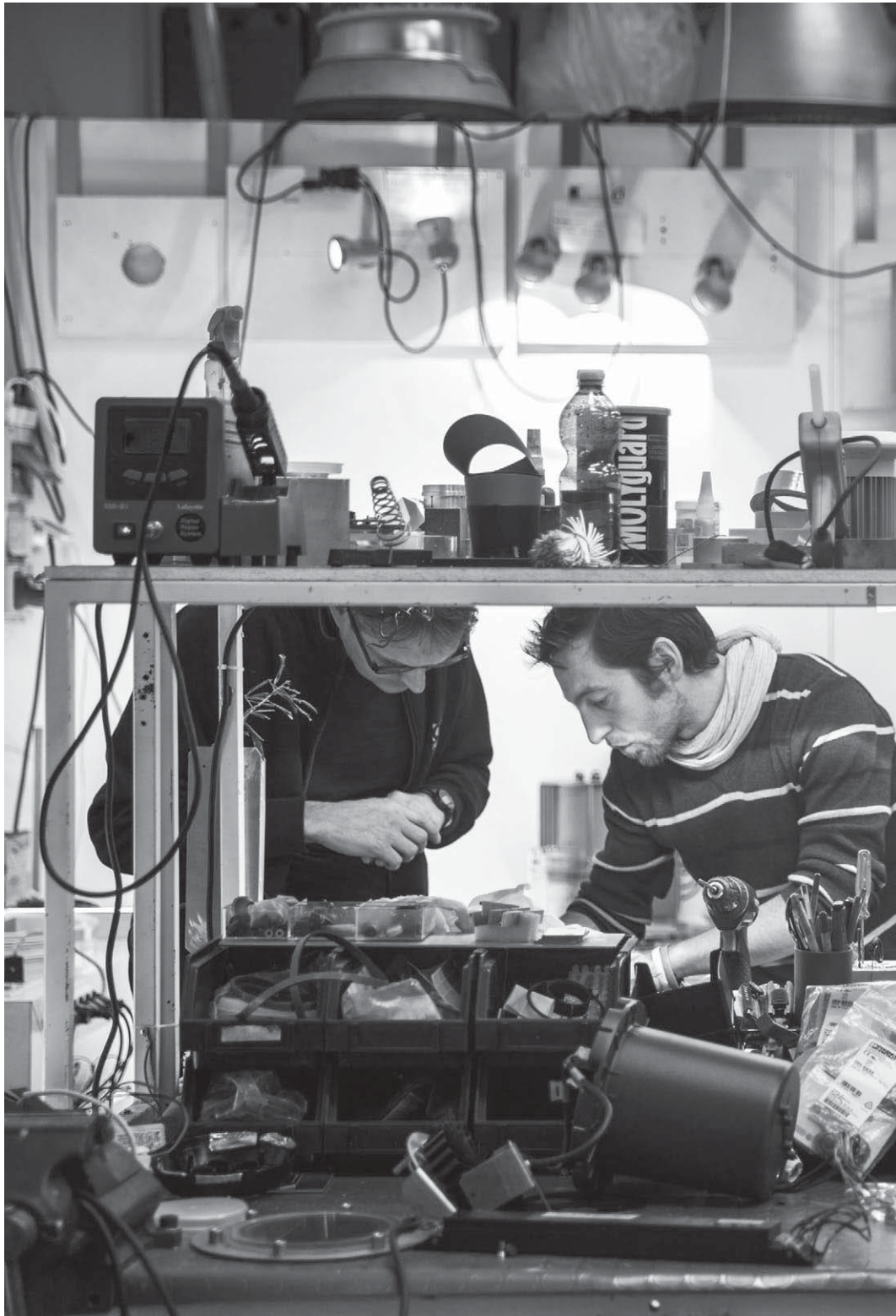



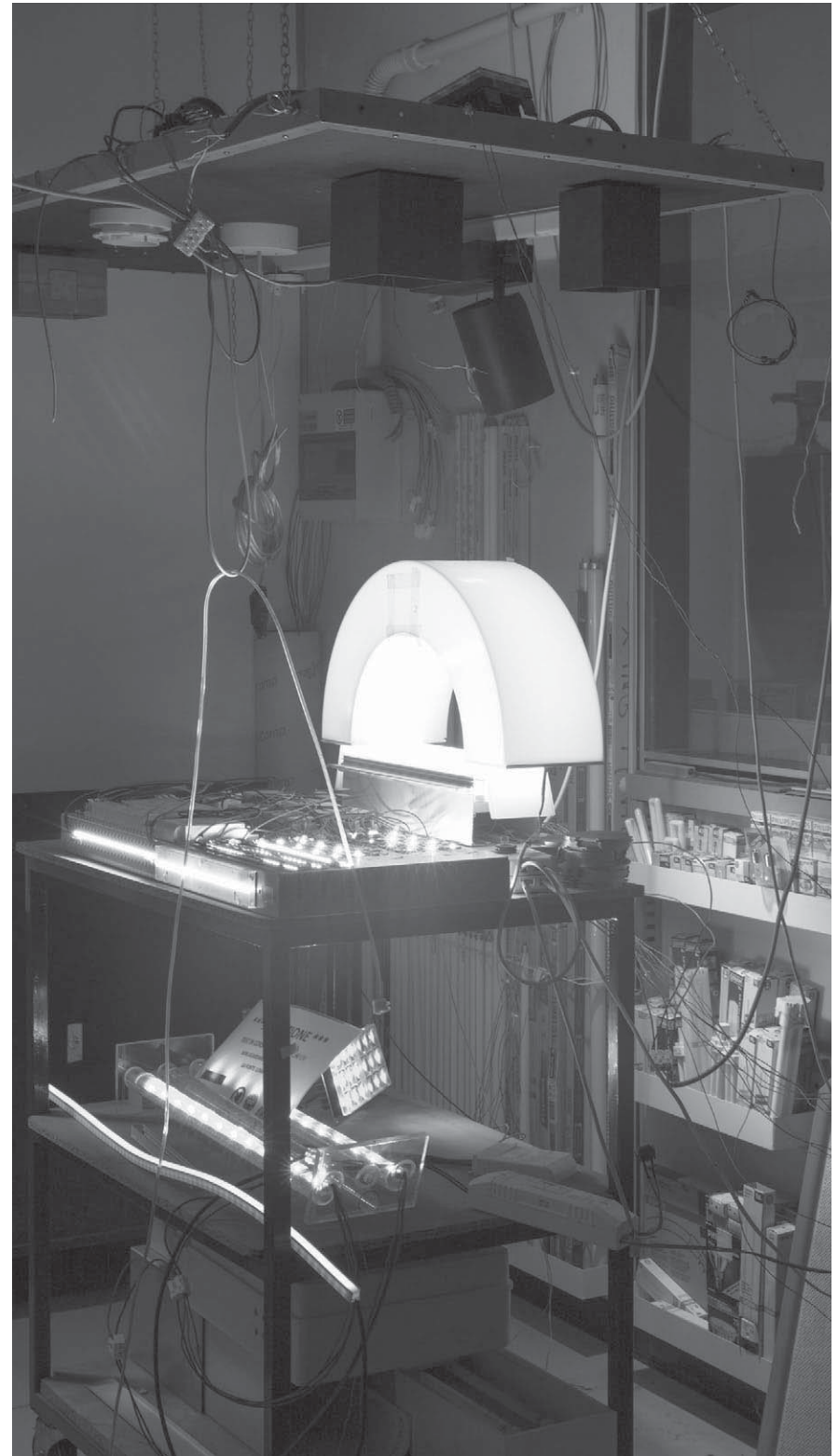

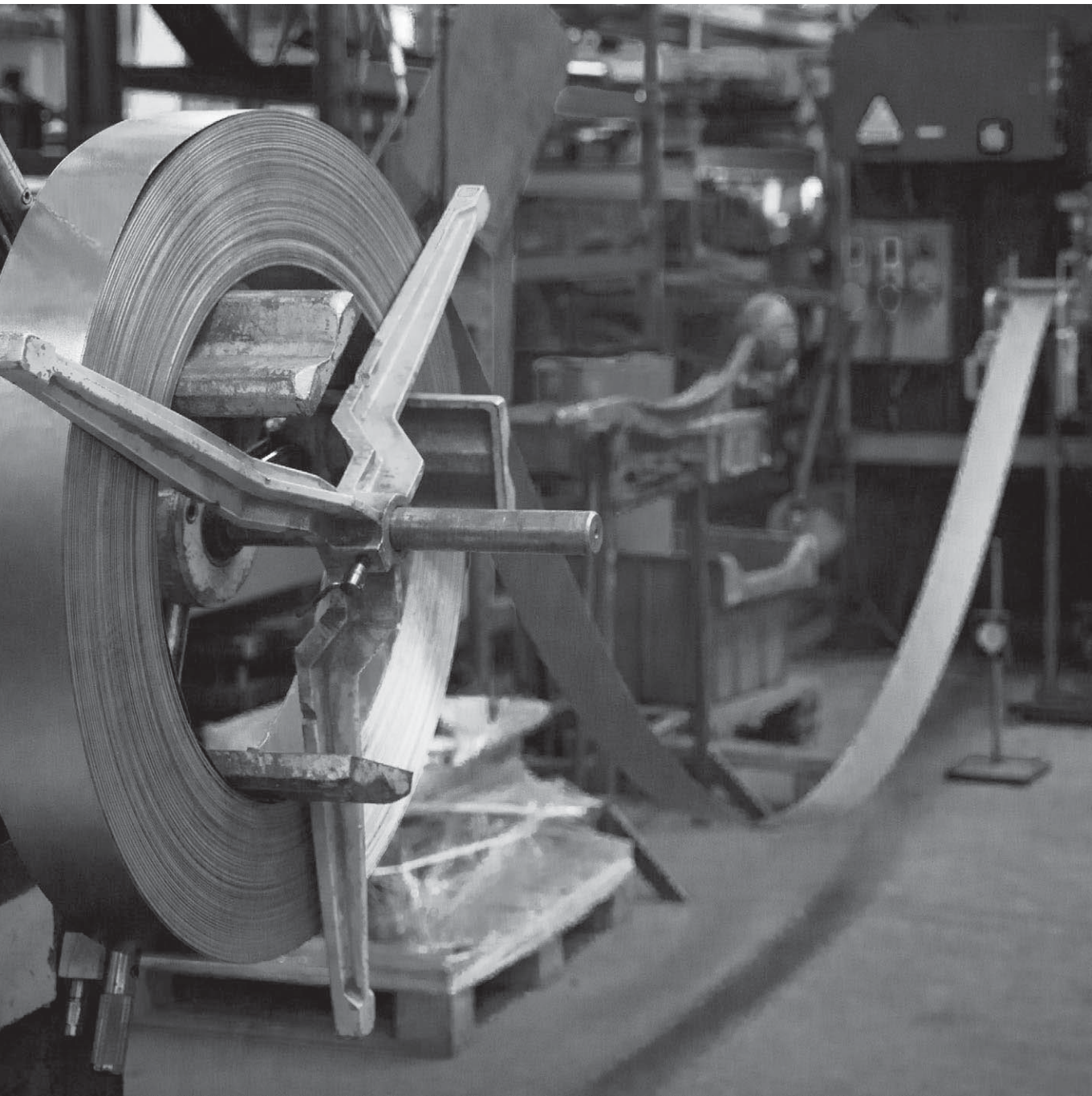



N 24° 28' 35" | E 54° 22' 12"



5

Abu Dhabi

## CLEVELAND CLINICS

Project by  
HDR Architecture

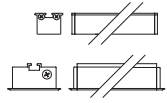
"THE TERM 'HOSPITAL OF THE FUTURE' IS USED QUITE OFTEN, BUT I CAN'T IMAGINE ANOTHER FACILITY THAT REFLECTS THAT PHRASE MORE THAN THE CLEVELAND CLINIC ABU DHABI," SAYS MOHAMMED AYOUB, LEAD HDR DESIGNER FOR THE PROJECT. "IT'S A BUILDING THAT BLENDS CUTTING-EDGE TECHNOLOGY, EVIDENCE-BASED DESIGN, WORLD-CLASS CARE, AND ARABIC CULTURE WITH ELEGANT ARCHITECTURE, CREATING A FACILITY THAT LOOKS MORE LIKE A SEVEN-STAR HOTEL THAN A HOSPITAL."

INSTALLED LAMPS	
<p>FILO</p> 	<p>CEILING/WALL RECESSED LENGTH CUSTOMIZABLE LED UP TO 20W/m</p> <p>Natural anodised extruded aluminium structure. Satin-finish extruded PMMA diffuser.</p>
<p>F0-F1</p> 	<p>GROUND RECESSED CONTINUOUS LINE LED BLUE - 38W/m.</p> <p>Stainless steel led lighting system with blue led provided with channel for cables.</p>
<p>ADDITIONAL CUSTOM MADE PRODUCTS ACCORDING TO DESIGNER'S AND ARCHITECT'S PROJECT</p>	

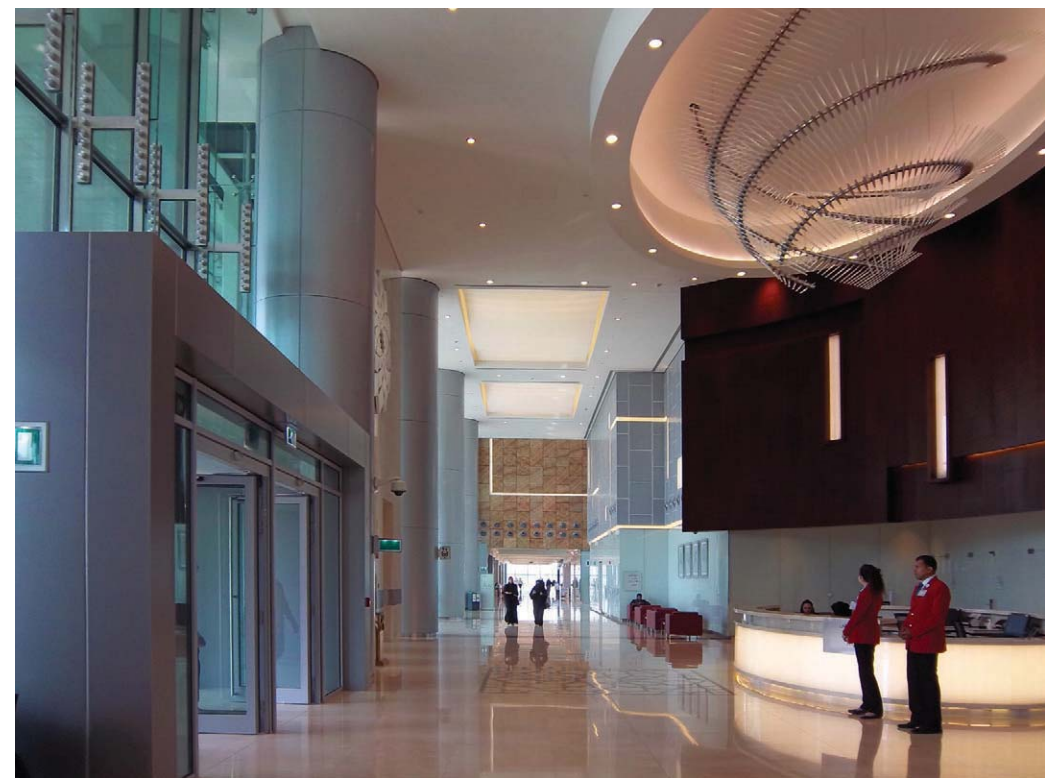





N 41° 53' 35" | E 12° 28' 58"





6

Roma

## ASI / AGENZIA SPAZIALE ITALIANA

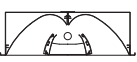
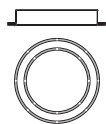
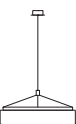
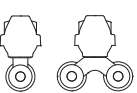
Project by  
5+1 AA Alfonso Femia Gianluca Peluffo

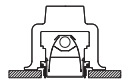
THE ABSENCE OF GRAVITY IS THE METAPHOR OF THIS PROJECT: A JOYFUL FLOATING WHICH SUDDENLY FINDS A MOMENTARY BALANCE. IT IS A DISSOCIATED BALANCE, NOT BASED ON SYMMETRY, NOR ON WEIGHT BALANCING. IT IS BASED ON MASSES SUSPENSION, REPRESENTING A PERCEIVING SYSTEM OF MOVEMENT AND CONNECTION. A BUILDING THAT CATALYZES THE CENTRIPETAL POWER OF SELF-REVELATION OF THE LANDSCAPE THROUGH ITS FRAGMENTS BLACKS, EXISTING.

INSTALLED LAMPS			
<p>DEA</p> 	<p>CEILING RECESSED Direct and reflected indirect light emission - T5 Light is perceived as being more balanced than light emitted by an equivalent conventional direct lighting system.</p>	<p>BUBBLE UP</p> 	<p>BUBBLE 600</p> 
<p>DELTA</p> 	<p>WATERPROOF IP65 - T5 OR LED  In sight lamps. Diffused and direct light emission.</p>	<p>CEILING RECESSED FOUR AVAILABLE SIZES LED UP TO 218W/m  Smooth opal polycarbonate diffuser.</p>	<p>SUSPENSION DIAMETER 600 - 1000 - 1800 - 3000 mm  Smooth opal polycarbonate diffuser, injection moulded, shock-resistant, anti-ageing.</p>
<p>BLADE</p> 	<p>SUSPENSION DIFFERENT OPTICS - T5  Blade continuous enables creating real architectures of light.</p>	<p>ON OFF</p> 	<p>SUSPENSION HIGH EFFICIENCY - T5  Visual comfort with reductions in luminance levels in upper emission corners.</p>
<p>SL</p> 	<p>CEILING RECESSED  More than 100 lumen/Watt LED UP TO 26W TXT-L optical systems guarantees ideal luminance control even for spaces with video terminal use.</p>	<p>ADDITIONAL CUSTOM MADE PRODUCTS ACCORDING TO DESIGNER'S AND ARCHITECT'S PROJECT</p>	







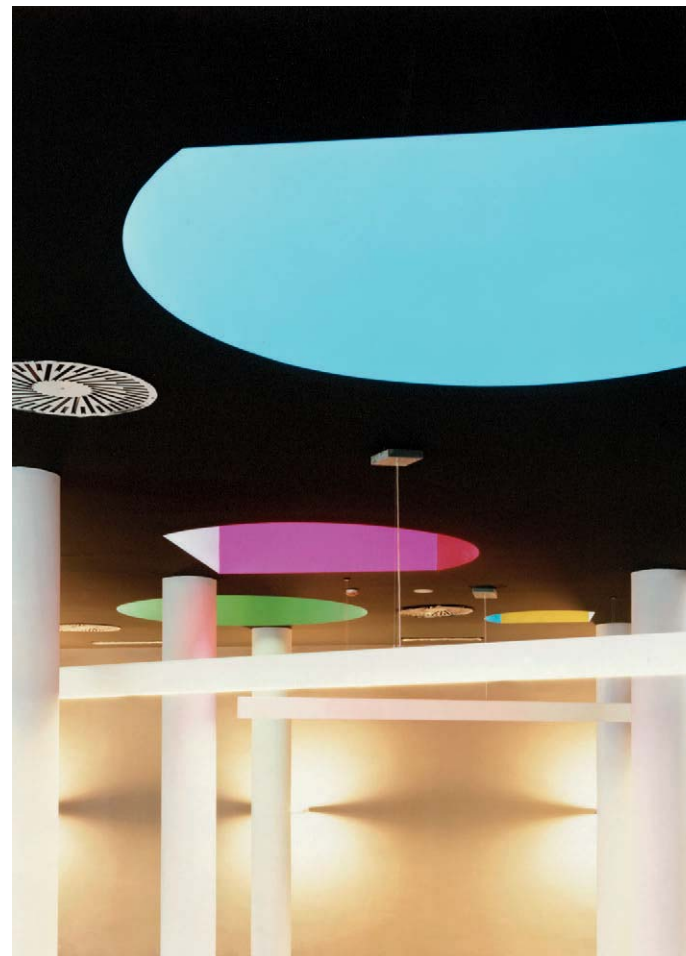
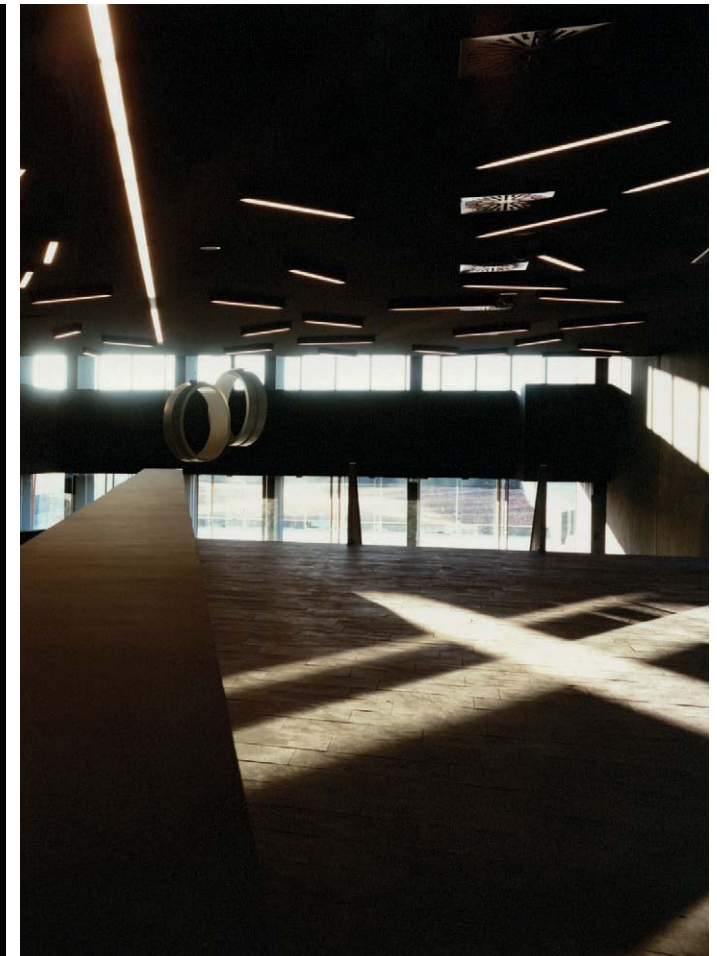
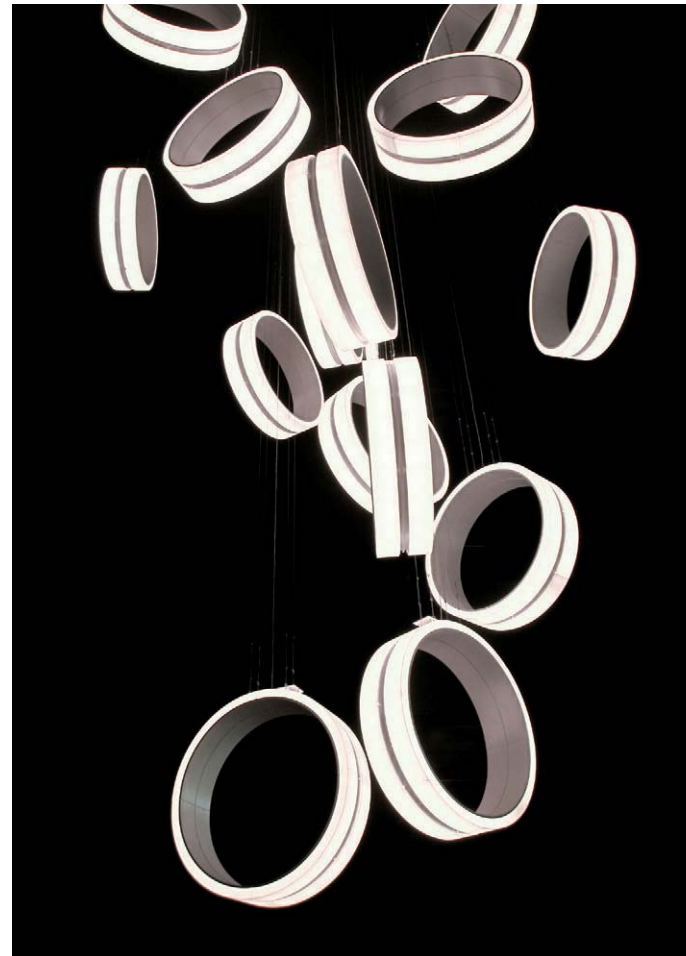





N 48° 13' 00" | E 15° 21' 00"

7  
Melk

## STIFT MELK

Project by  
Wehdorn Architekten, Ziviltechniker GmbH and Elcons Gebäudetechnik Eigenthaler u. Lagler OG  
ND Beleuchtungs Technik

MELK ABBEY IS A BENEDICTINE ABBEY IN AUSTRIA, AND AMONG THE WORLD'S MOST FAMOUS MONASTIC SITES. THE ABBEY CONTAINS THE TOMB OF SAINT COLOMAN OF STOCKERAU AND THE REMAINS OF SEVERAL MEMBERS OF THE HOUSE OF BABENBERG, AUSTRIA'S FIRST RULING DYNASTY. IN HIS WELL-KNOWN NOVEL THE NAME OF THE ROSE, UMBERTO ECO NAMED ONE OF THE PROTAGONISTS "ADSON VON MELK" AS A TRIBUTE TO THE ABBEY AND ITS FAMOUS LIBRARY.

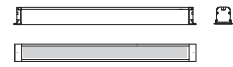
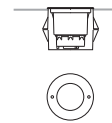
INSTALLED LAMPS	
<p>D49_NASTER</p> 	<p>CEILING RECESSED IP67 - LED UP TO 54W</p> <p>Tempered safety glass - 8 mm thickness, mechanical and thermal shock resistant.</p>
<p>D44_TELLUX T3</p> 	<p>GROUND RECESSED IP67 - LED UP TO 37W</p> <p>Tempered safety glass - 12mm thickness, mechanical and thermal shock resistant.</p>







8

Torino

## PALAVELA

Project by  
Gae Aulenti Architetti Associati

THE CONVERSION OF TURIN'S PALAVELA, INTO AN OLYMPIC ICE STADIUM, IS AN ARCHITECTURAL AND TECHNICAL MASTERPIECE. SITUATED IN TURIN, THE PALAVELA HAS ALWAYS FASCINATED VISITORS. THE MAIN BUILDING IS LOCATED WITHIN A 150 M DIAMETER CIRCLE, AND CONSISTS OF A STRUCTURE RESTING ON JUST THREE BEARING POINTS. GAE AULENTI HAS SUCCEEDED IN REVITALISING A TRADITIONAL BUILDING, IN SUCH A MANNER, THAT IT WILL BE A FUNCTIONING ARCHITECTURAL HIGHLIGHT IN TURIN FOR MANY DECADES TO COME.

### INSTALLED LAMPS

D12\_DADO

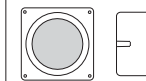

WALL RECESSED  
IP65 - FLU UP TO 18W

Safety tempered glass, thermal shock resistant. Directional anti-glare grid.





N 41° 23' 19" | E 02° 09' 32"

9

Barcelona

## IM CLINIC

Project by  
Mario Corea Arquitectura

SITUATED IN FRONT OF COLLSEROLA, THE MOUNTAIN RANGE THAT MARKS THE WESTERN LIMIT OF BARCELONA, THE VALL D'HEBRON HOSPITAL COMPLEX IS ONE OF THE MOST IMPORTANT AND LARGEST HEALTHCARE CENTERS IN SPAIN. THE GYMNASIUM THAT HAD BEEN STANDING ON THE RATHER CONSTRICTED SITE HAD BEEN DEMOLISHED AND ALL THAT REMAINED OF IT WAS THE BASEMENT IN WHICH THE DEPARTMENT'S ARCHIVES WERE STORED.

### INSTALLED LAMPS

#### BUBBLE UP

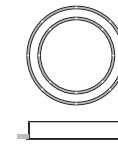

CEILING RECESSED  
FOUR AVAILABLE SIZES  
LED UP TO 218W/m

Smooth opal polycarbonate  
diffuser.

#### BUBBLE

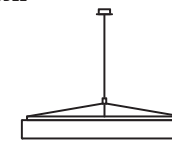

SUSPENSION

Smooth opal polycarbonate  
diffuser, injection moulded,  
shock-resistant, anti-ageing.

#### PURA



CEILING RECESSED  
High IP for clean rooms - T5

VD Planirex diffuser made of 3  
mm thick transparent tempered  
glass panel.







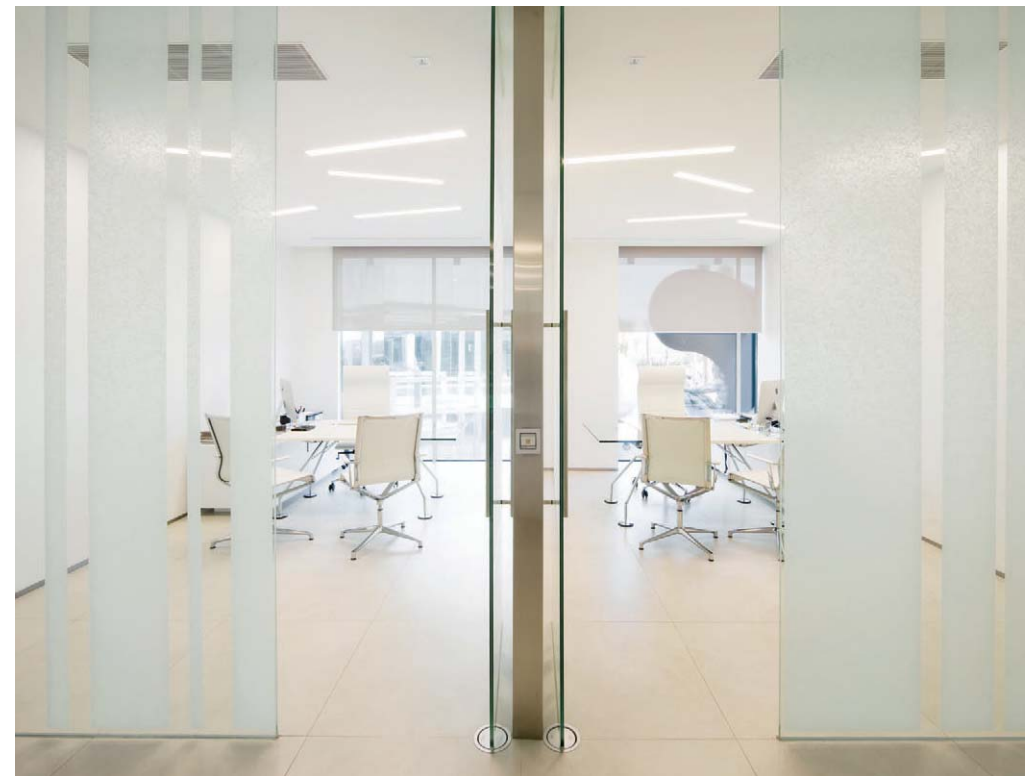



N 24° 28' 35" | E 54° 22' 12"

10

Abu Dhabi

## SKY TOWER SHAMS

Project by  
Arquitectonica

SKY TOWER IS THE TALLER OF TWO TOWERS THAT RISE ALONGSIDE THE MONUMENTAL PORTICO OF THE GATE PROJECT LIKE WELCOMING TORCHES. THE FAÇADES OF THE TOWERS ARE ADORNED WITH A SERIES OF CRYSTALS THAT SPARKLE IN THE SUNLIGHT. THE ELLIPTICAL SHAPE REDUCES WIND RESISTANCE AND ITS PERIMETER COLUMNS PROVIDE A TUBE STRUCTURE EFFECT. THE RESIDENCES ARE DESIGNED TO OFFER THE BEST VIEW. THE FAÇADE CURVATURE EMPHASIZES THE PANORAMIC PERSPECTIVE.

### INSTALLED LAMPS

BUBBLE UP 1800

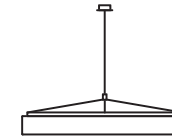

SUSPENSION/CEILING  
DIAMETER 1800mm - LED 291W

Smooth opal polycarbonate  
diffuser, injection moulded,  
shock-resistant, anti-ageing.

ADDITIONAL CUSTOM MADE  
PRODUCTS ACCORDING TO  
DESIGNER'S AND ARCHITECT'S  
PROJECT

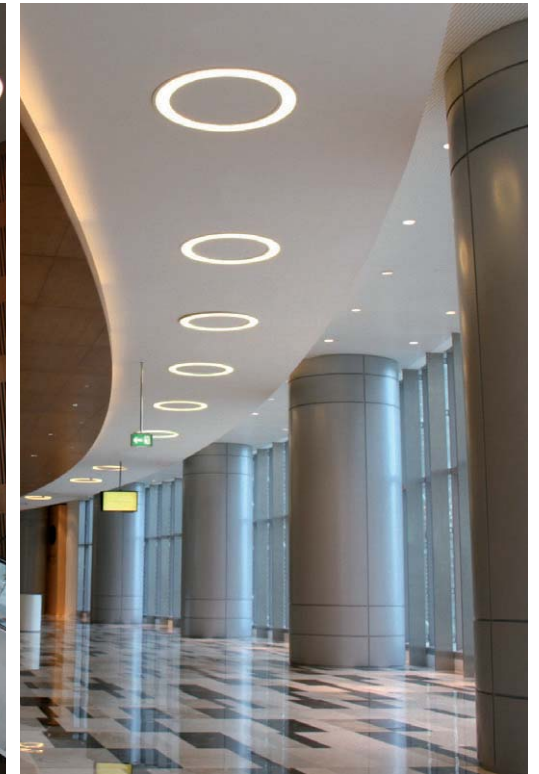



N 36° 18' 56" | E 59° 34' 04"

11

Mashhad

## IMAM REZA SHRINE – BABOL JAVAD ENTRANCE

Project by  
Girardi Associati

THE IMAM REZA SHRINE HAS GROWN SIGNIFICANTLY ALONG THE CENTURIES FROM THE MAUSOLEUM OF THE 8TH IMAM, TO ONE OF THE LARGEST RELIGIOUS COMPLEXES IN THE ISLAMIC WORLD. SINCE ITS ESTABLISHMENT, THE POLITICAL POWERS TO BE HAVE USED THE SACRED SPACE TO PROVE THEIR TEMPORAL POWER, CREATING SOME OF THE MOST ASTOUNDING WONDERS OF ISLAMIC ART.

### INSTALLED LAMPS

D20\_DUETTO T3

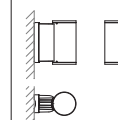

WALL MOUNTED  
IP66 - LED UP TO 45W

Safety tempered glass  
diffusers. Extra-pure  
aluminium reflector.





N 47° 14' 55" | E 06° 01' 05"

12

Besançon

## PLATEAU SPORTIF AVANNE-AVENEY

Project by  
Machurey Groupe Architectes

WE HAD TO REDUCE THE VISUAL BARRIERS AND IMPROVE LANDSCAPE QUALITY OF THE SITE. WHATEVER IT TAKES OPEN THE VIEW, OPEN THE PASSAGE, GIVE WAY TO THE THROUGH LIGHT AND AGAIN ANNOUNCE THE PICTURESQUE HOUSES AND MORE DISTANT THE ARRIVAL OF THE VALLEYS. IT IS THE DOUBTS THAT DICTATES THE MEASURE OF THE WORLD. IT IS THE SEASON WHERE FLOODS ARE CHANGING THE LANDSCAPE AND SIGN AMAZING CURVES IN THE CLAY ONCE REMOVED.

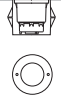
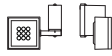
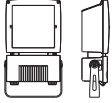
INSTALLED LAMPS	
<p>D44_TELLUX T3</p> 	<p>GROUND RECESSED IP67 - LED UP TO 37W</p> <p>Tempered safety glass - 12mm thickness, mechanical and thermal shock resistant.</p>
<p>D55_FLEX Q2</p> 	<p>SPOT LIGHTS IP65 - LED UP TO 52W</p> <p>Rotation on 2 axes 360°-130°</p>
<p>D30_BOXER</p> 	<p>SPOT LIGHTS IP66 - LED UP TO 84.5W</p> <p>Total mechanical resistance, perfect corrosion resistance and excellent luminous output</p>





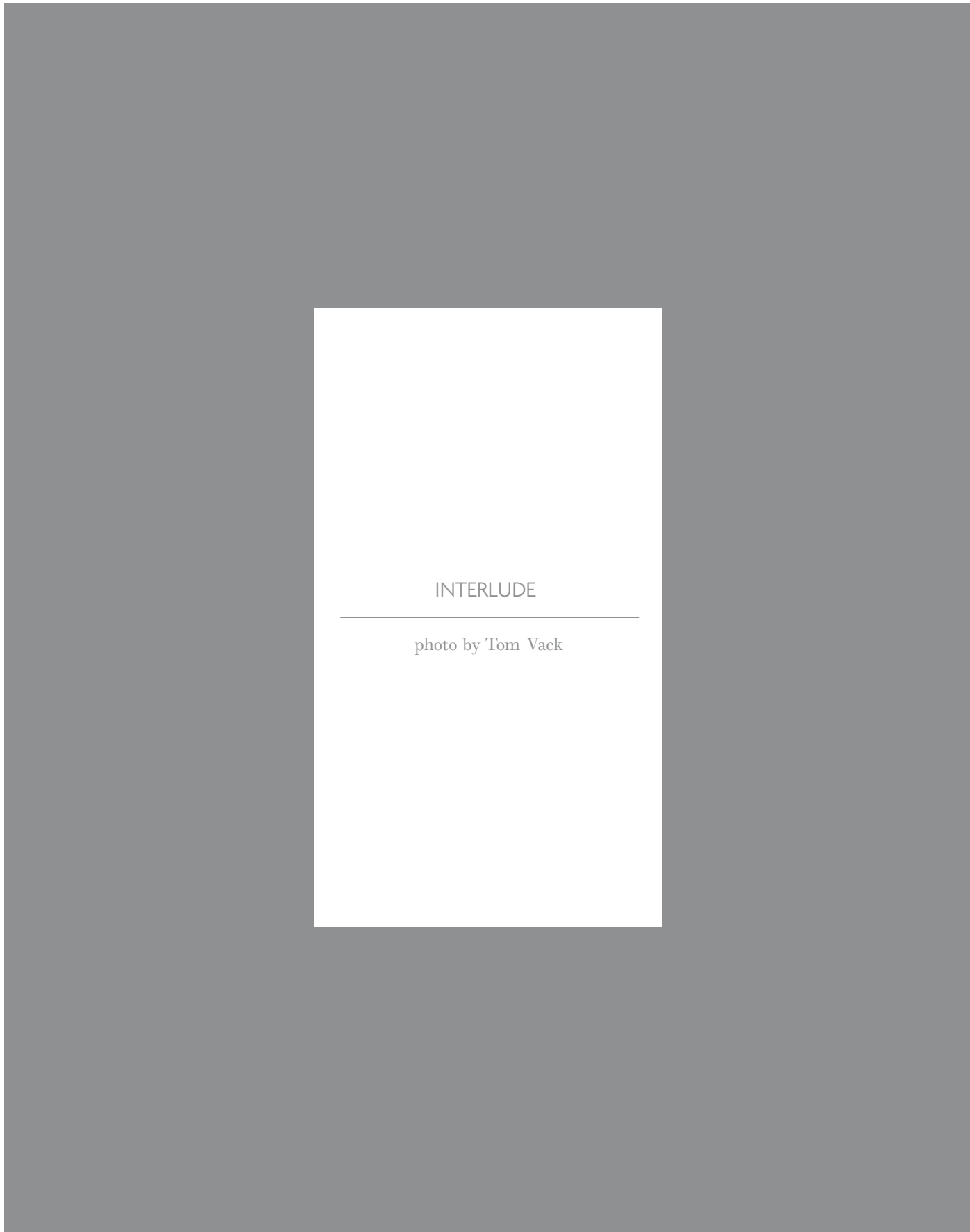

INTERLUDE

---

photo by Tom Vack

















N 45° 38' 04" | E 12° 33' 55"

13

San Donà di Piave

## NEIGHBORHOOD PARK

Project by  
Cino Zucchi Architetti

A SPIRALLING WOODEN SCREEN SHELTERS A PLAYGROUND LIT BY A HIGH LAMP POLE IN THE SHAPE OF A SPROUT. A SERIES OF "RIPPLES" IN THE CONCAVE HIGHER SLOPE ACT AS AN INFORMAL AMPHITHEATRE FOR EVENTS, AND THEIR CENTRAL CROSSED HEIGHT OFFSET CREATE A LOW-PITCHED RAMP FOR WHEELCHAIRS. THE HEIGHT OF THE EARTH MOUNDS WHICH EMBRACE THE WIDE CENTRAL MEADOW IS STUDIED TO PROTECT THE SPACE FROM THE SURROUNDING DISORDER BUT NOT TO SCREEN OFF THE VIEW FROM AND TO THE HOUSES.

### INSTALLED LAMPS

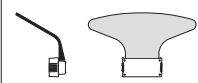
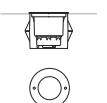
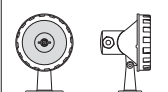
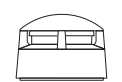
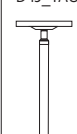
<p>D21_DUPLO</p> 	<p>POLE MOUNTING IP65 - LED UP TO 56W</p> <p>Safety tempered glass diffusers with extra-pure aluminium reflector.</p>	<p>D44_TELLUX T3</p> 	<p>GROUND RECESSED IP67 - LED UP TO 37W</p> <p>Tempered safety glass - 12mm thickness, mechanical and thermal shock resistant.</p>
<p>D17_TARZAN</p> 	<p>UNDERWATER IP68 - LED 9W</p> <p>Designed to meet the requirements of a safe and scenic underwater lighting.</p>	<p>D31_ZACK</p> 	<p>LOW POLE/BOLLARD IP67 - LED 25W</p> <p>Super compact vandal-proof lighting with different types of bulbs and darkening sectors.</p>
<p>D43_TAU</p> 	<p>POLE MOUNTING IP65 - LED 36W</p> <p>Totally glare-free softly diffused light, design together with high quality materials.</p>	<p>ADDITIONAL CUSTOM MADE PRODUCTS ACCORDING TO DESIGNER'S AND ARCHITECT'S PROJECT</p>	





N 45° 27' 51" | E 09° 11' 22"

14

Milano

IULM

Project by  
5+1 AA Alfonso Femia Gianluca Peluffo

OUTSKIRTS BECOME ALMOST CENTRE. A BUILDING WHICH IS NOT ACCIDENTALLY LOCATED INSIDE A LOT, AS THE MODERNITY IN EVERYTHING, BUT THAT CONSTITUTES FULL AND EMPTY SPACES IN THE SAME WAY. A MIMETIC BUILDING IN RESPECT TO THE SURROUNDING AREA. BRICKS, EXPOSED CONCRETE, GLASS, PLASTER. IN THE INSIDE PART AN EXPLOSION OF EMERALD GREEN CERAMICS. AS A TRAFFIC LIGHT IN THE FOG.

INSTALLED LAMPS

QUINDICI



DIRECT OR DIRECT/INDIRECT EMISSION - T5

Quindici is product with a high aesthetic content, flexible, adjustable with large dimensions.

VICELIGHT

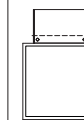

EMERGENCY CEILING IP40 - 1W

PMMA diffuser made of 15 mm thick transparent crystal methacrylate for light refraction and vertical emission.

DELTA

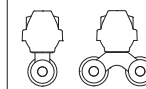

WATERPROOF IP65 - T5 OR LED

In sight lamps. Diffused and direct light emission.

SLEVO

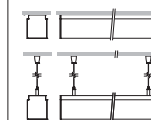

HIGH EFFICIENCY CEILING/ SUSPENSION LED UP 73W

Visual comfort with reductions in luminance levels in upper emission corners.

D49\_NASTER



GROUND RECESSED IP67 - LED UP TO 54W

Tempered safety glass - 8 mm thickness, mechanical and thermal shock resistant.

D30T\_BOXER/T



SPOT LIGHTS IP66 - METAL HALIDE UP TO 150W

Total mechanical resistance, perfect corrosion resistance and excellent luminous output.

D34\_SEGNATORI



AVIATION OBSTRUCTION WARNING LIGHTS IPP - LED 8W

Unbreakable polycarbonate anti UV globe. High emission LED-red light.

ADDITIONAL CUSTOM MADE PRODUCTS ACCORDING TO DESIGNER'S AND ARCHITECT'S PROJECT







N 29° 22' 11" | E 47° 58' 42"



15

## Kuwait City

### SAFAT HOME

Project by  
Alghanim Industries

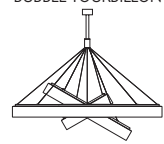
THE RECENTLY REFURBISHED SAFAT HOME IN SHUWAIKH FEATURES A SPACIOUS SHOWROOM THAT CONTAINS ALL YOUR HOME NEEDS FROM TILES AND SANITARY TO HOME DÉCOR AND FURNISHINGS. THE LIGHT EXPERIENCE IS WONDERFUL: UNIFORMITY AND LED WITH HIGH COLOUR RENDERING CREATE EVOCATIVE SCENERIES.

INSTALLED LAMPS	
<p><b>BUBBLE TOURBILLON</b></p>  <p>SUSPENSION CONFIGURATION CUSTOMIZABLE - LED UP TO 1055W</p> <p>Smooth opal polycarbonate diffuser, injection moulded, shock-resistant, anti-ageing.</p>	<p><b>SLEVO CEILING</b></p>  <p>HIGH EFFICIENCY LED UP 73W</p> <p>Visual comfort with reductions in luminance levels in upper emission corners.</p>





N 45° 27' 51" | E 09° 11' 22"



16

Milano

## CITY LIFE

Project by  
Studio Libeskind

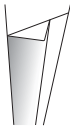
IN 2004 STUDIO LIBESKIND, IN CONJUNCTION WITH ZAHA HADID ARCHITECTS AND ARATA ISOZAKI & ASSOCIATES, WON THE COMPETITION FOR A MASTER PLAN TO DEVELOP AND RECONNECT THE EXISTING CITY FABRIC OF MILAN TO AN ABANDONED 61 ACRE SITE, FORMERLY HOME TO THE FIERA MILANO, THE CITY'S HISTORIC FAIRGROUNDS.

INSTALLED LAMPS	
<p>APERIO</p>  <p>WALL RECESSED BLUETOOTH OR DALI REMOTE CONTROL - LED 56W</p> <p>Co-extruded polycarbonate diffuser satin finished, with special internal reflecting surface.</p>	<p>FILO</p>  <p>CEILING CUSTOM LENGHT - LED 20W/m</p> <p>Satin-finish extruded PMMA diffuser.</p>



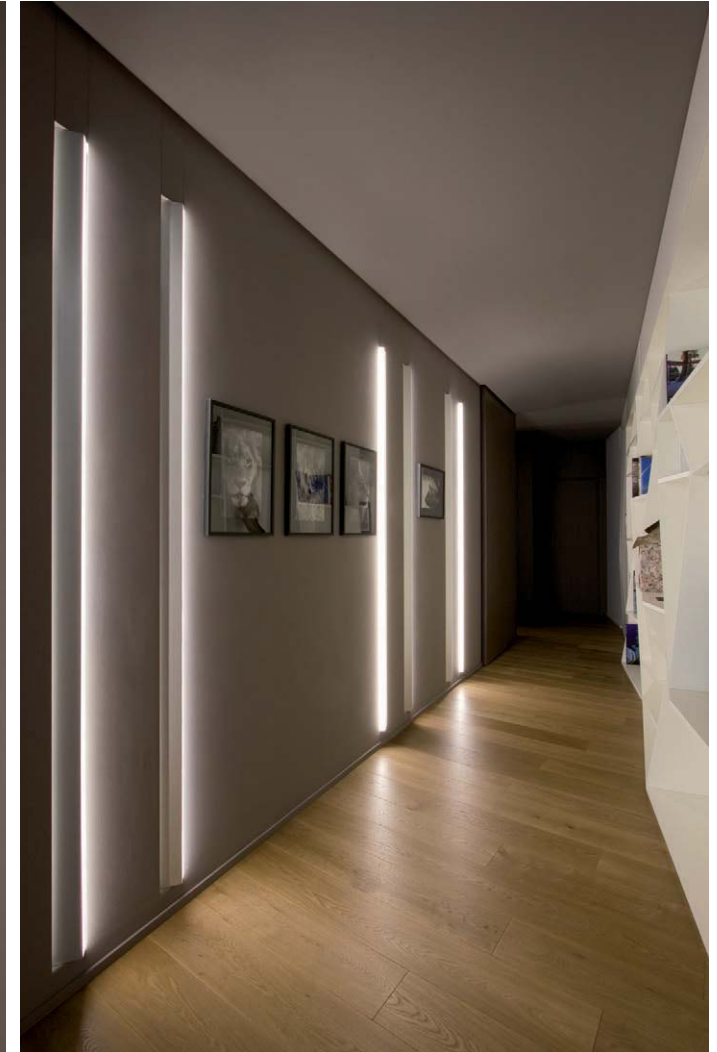

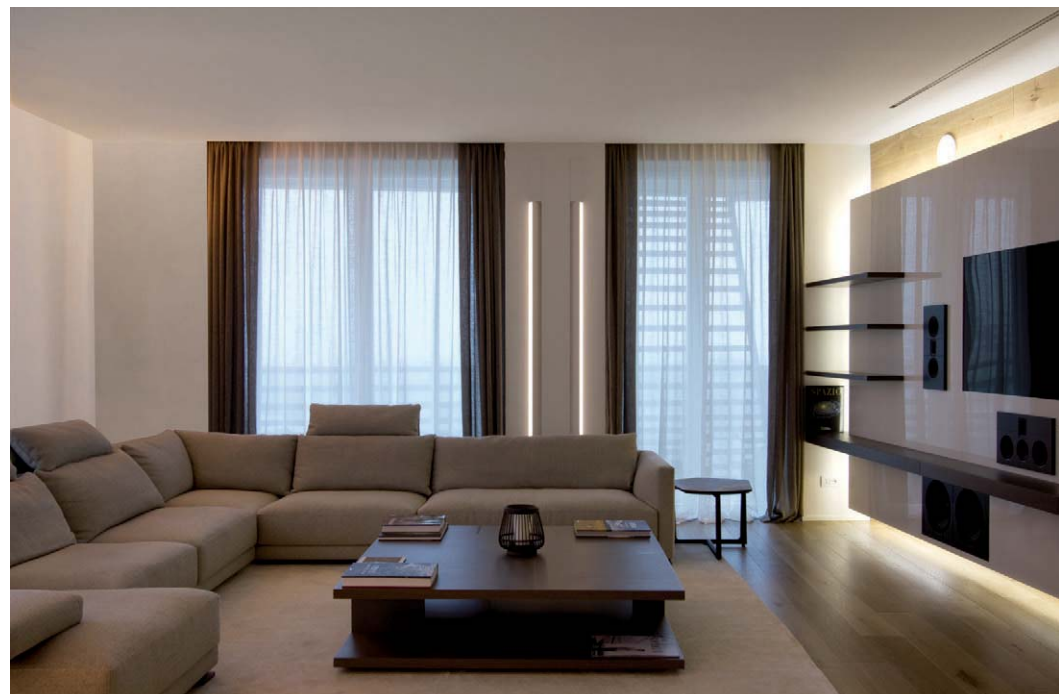



N 45° 35' 00" | E 09° 31' 00"

17

Vaprio d'Adda

## BENNET VAPRIO D'ADDA (MI)

Project by  
Studio Cotefa Ingegneri e Architetti

BENNET IS A HYPERMARKET CHAIN WITH OVER 59 RETAIL LOCATIONS IN NORTHERN ITALY. THE BUSINESS WAS FOUNDED BY ENZO RATTI IN 1964 AT COMO AND THE HEAD OFFICE IS STILL LOCATED IN NEARBY MONTANO LUCINO. LIGHT IS LIGHT IS A KEY ELEMENT IN THE CUSTOMER EXPERIENCE; IT MUST GIVE MODERNITY AND SAFETY.

### INSTALLED LAMPS

D67\_TEMA

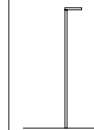

POLE MOUNTING  
IP65 - LED UP TO 83W

The system is made of pole-mounted and wall light fixtures with an essential design, studied for urban lighting.

SLED CUSTOM



CEILING RECESSED  
IP65 - 165W

Custom product for Alucobond ceiling, powerful and IP rated, equipped with dark optics for reducing glare.







N 51° 30' 30" | W 00° 07' 32"

18

London

## UNIVERSITY OF WESTMINSTER

Project by  
R&D

A VIBRANT LEARNING ENVIRONMENT – FOSTERING INNOVATION AND CREATIVITY, INFORMED BY PRACTICE, INSPIRED BY RESEARCH, FOCUSING ON THE GLOBALLY RELEVANT AREAS IN WHICH WE EXCEL.  
WE ARE BUILDING THE NEXT GENERATION OF HIGHLY EMPLOYABLE GLOBAL CITIZENS WHO WILL SHAPE THE FUTURE.

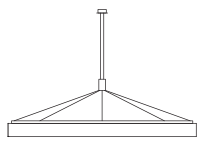
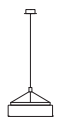
INSTALLED LAMPS	
<p><b>BUBBLE 3000</b></p>  <p>SUSPENSION DIAMETER 3000mm LED 600W</p> <p>Smooth opal polycarbonate diffuser, injection moulded, shock-resistant, anti-ageing.</p>	<p><b>BUBBLE 600</b></p>  <p>SUSPENSION/CEILING DIAMETER 600mm - LED 55W</p> <p>Smooth opal polycarbonate diffuser, injection moulded, shock-resistant, anti-ageing.</p>

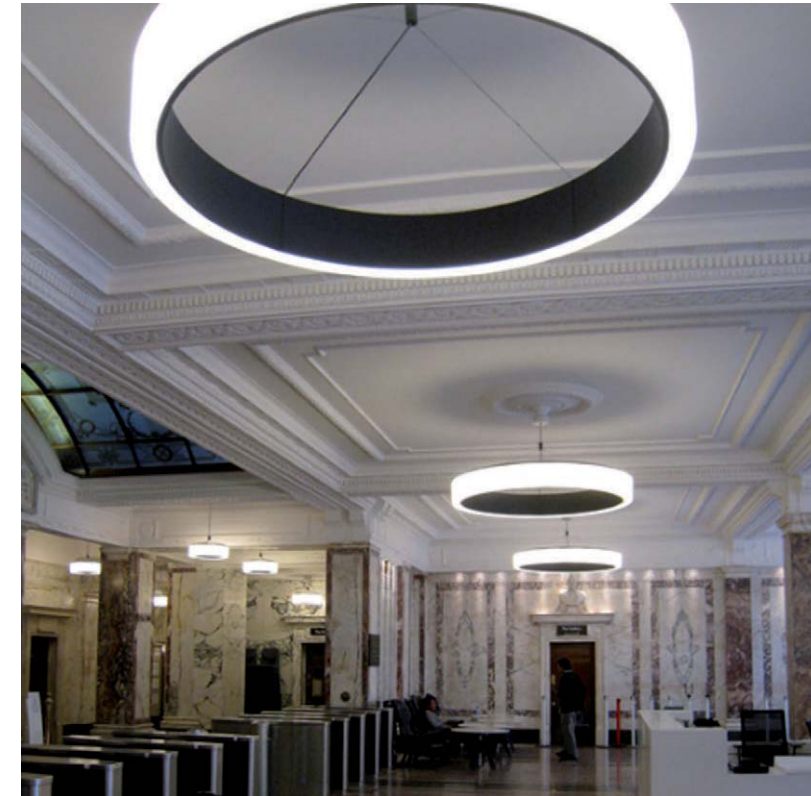



19

Stockholm

## LITOGRAFISKT MUSEUM GRUDES ATELJE & STENTRYCKER

Project by  
Bertil Schroder

THE MUSEUM OF LITHOGRAPHY IS A COMBINED MUSEUM AND WORKSHOP SPECIALIZED IN STONE PRINTING. THE MUSEUM SHOWS THE FANTASTIC STORY OF THE ORIGIN OF OUR MODERN COMMUNICATION SOCIETY. THE LITHOGRAPHERS WERE PROUD PROFESSIONALS WHO WITH PLEASURE SAVED EXAMPLES OF WELL DONE WORKS. THE GOAL IS TO KEEP THE ART OF LITHOGRAPHY ALIVE.

### INSTALLED LAMPS

D23\_MINISOSIA



SUSPENSION  
IP20 - LED 28W

Safety tempered protective glass, with light diffusing texture. Extra-pure aluminium reflector.

N 59° 19' 57" | E 18° 03' 53"









N 59° 21' 25" | E 18° 00' 53"

20  
Solna

## ULRIKSDALS

Project by  
Petra Gipp Arkitektur

THE SERVICE BUILDING AT ULRIKSDAL CEMETERY INSERTS ITSELF IN THE RICH, MAGNIFICENT NATURE OF THE SITE. THE BUILDING FORMS AN ENTRYWAY INTO THE PARK AND CEMETERY. A BUILDING THAT STATES ITS PRACTICAL FUNCTION AND DRAWS ON THE INDUSTRIAL BUT ALSO EXPRESSES SOMETHING OF PRIDE AND EASE, WHICH RESONATES WITH THE FREE DESIGN OF THE CEMETERY.

### INSTALLED LAMPS

D30T\_BOXER/T

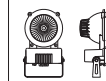

SPOT LIGHTS  
IP66 - METAL HALIDE UP TO 150W

Total mechanical resistance,  
perfect corrosion resistance  
and excellent luminous output.

D06\_SOSIA

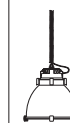

SUSPENSION  
IP65 - LED UP TO 80W

Tempered safety glass with  
extra-pure aluminium reflector.





N 43° 23' 51" | E 10° 26' 40"



21

Rosignano Marittimo

## BIBLIOTECA CIVICA ROSIGNANO MARITTIMO (LI)

Project by  
UNA2 Architetti Associati - Area progetti srl

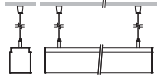
THE LIBRARY ITSELF IS A SYMBOL: KNOWLEDGE, AWARENESS, BROAD-MINDEDNESS, INTELLIGENT FRUITION OF RESOURCES; A SORT OF MONUMENT TO SUSTAINABILITY AND TO ENVIRONMENTAL RESPECT.

INSTALLED LAMPS	
<p><b>SLEVO</b></p>  <p>SUSPENSION HIGH EFFICIENCY LED UP 73W</p> <p>Visual comfort with reductions in luminance levels in upper emission corners.</p>	<p><b>D23_MINISOSIA</b></p>  <p>SUSPENSION IP20 - LED 28W</p> <p>UV-stabilized unbreakable opaline polycarbonate. Extra-pure aluminium reflector</p>
<p><b>D43_TAU</b></p>  <p>POLE MOUNTING IP65 - LED 36W</p> <p>Totally glare-free softly diffused light, design together with high quality materials.</p>	







© CASTALDI LIGHTING SPA

Via Benvenuto Cellini, 8  
21012 Cassano Magnago (Varese) Italy  
Tel: +39.0331.706.91  
Fax: +39.0331.706.999  
info@castaldilighting.it  
www.castaldilighting.it

#### PROJECT AND ART DIRECTION

R+W

#### GRAPHIC DESIGN

Antonio Zorzi | zazo.eu

#### PRINTED IN ITALY

Lazzati Industria Grafica  
February 2016

#### PHOTO CREDITS

NOTES FROM PRODUCTION / Adriano Brusaferrì  
INTERLUDE / Tom Vack

#### THANKS TO

Castaldi Lighting would like to thank the above mentioned architects, photographers, copyright holders and our partners involved in the creation of this book for the use of their material.  
We apologize for any possible omission from this list.

#### SOURCES AND PHOTO CREDITS

ABU DHABI INTERNATIONAL AIRPORT  
Source: KPF / Image courtesy of ADAC  
DOCKS DE MARSEILLE  
Source: 5+1AA / Image courtesy of 5+1AA - ©Luc Boegly  
ANKARA GATES  
Source: Citylight Professional Lighting Systems  
Image courtesy of Citylight  
INGERSOLL RAND HEADQUARTERS  
Source: Studio Fusion / Image courtesy of Betacalco  
CLEVELAND CLINICS  
Source: HDR Architecture  
Image courtesy of Cleveland Clinic Abu Dhabi  
ASI / AGENZIA SPAZIALE ITALIANA  
Source: 5+1AA / ©Daniele Domenicali - ©Ernesta Caviola  
STIFT MELK  
Image courtesy of ND Beleuchtungstechnik  
PALAVELA  
Source: Kawneer / Image courtesy of Gae Aulenti Architetti associati - ©Roland Halbe  
IM CLINIC  
Source: Mario Corea arq. / Image courtesy of Espacio Aretha  
SKY TOWER SHAMS  
Source: skyscrapercenter.com  
IMAM REZA SHRINE  
Source: Ajam Media Collective / Image courtesy of TiSerra  
PLATEAU SPORTIF AVANNE-AVENEY  
Source: Machurey Groupe Architectes / Image courtesy of Marvall  
NEIGHBORHOOD PARK  
Source: Cino Zucchi Architetti  
Image courtesy of Cino Zucchi Architetti  
IULM  
Source: 5+1AA  
Image courtesy of 5+1AA - ©Ernesta Caviola  
SAFAT HOME  
Source: Safat Home / Image courtesy of Alghanim Industries  
CITY LIFE  
Source: Studio Libeskind / Image Castaldi Lighting  
BENNET VAPRIO D'ADDA  
Source: Cotefa.ingegneri&architetti  
Image courtesy of Bennet S.p.A.  
UNIVERSITY OF WESTMINSTER  
Source: University of Westminster  
LITOGRAFISKT MUSEUM  
GRUDES ATELJE & STENTRYCKERI  
Source: The Museum of Lithography  
Image courtesy of Annell - ©Åke E:son Lindman  
ULRIKSDALS  
Source: Petra Gipp Arkitektur  
Image courtesy of Annell - ©Åke E:son Lindman  
BIBLIOTECA CIVICA ROSIGNANO MARITTIMO  
Source: SBChallenge11/ Image courtesy of Una2 - ©A. Bosio



